



Level



Pressure



Flow



Temperature

Liquid
Analysis

Registration

Systems
Components

Services



Solutions

Technical Information

Proline Prowirl 72F, 72W, 73F, 73W

Vortex Flow Measuring System

Reliable flow measurement of gas, steam and liquids



Application

For the universal measurement of the volume flow of gases, steam and liquids.

With integrated T-measurement, the mass flow of steam, water (as per IAPWS-IF97 ASME), natural gas (as per AGA NX-19), compressed air and other gases and liquids can be measured.

Maximum range of applications thanks to:

- Fluid temperature range from $-200...+400$ °C
- Pressure ratings up to PN250/Cl 1500

Approvals for hazardous areas:

- ATEX, FM, CSA, TIIS

Connection to all common process control systems:

- HART, PROFIBUS PA, FOUNDATION Fieldbus

Relevant safety aspects:

- Pressure Equipment Directive
- Up to SIL 2

Your benefits

The robust **Prowirl sensor**, tried and tested in over 100,000 applications offers:

- High resistance to:
 - Vibrations (over 1 g in all axes)
 - Temperature shocks (> 150 K/s)
 - Contaminated media
 - Water hammer
- No maintenance, no moving parts, no zero-point drift.
- Software initial settings save time and costs

In addition, Prowirl devices offer the following possibilities:

- Complete saturated steam or liquid-mass measuring point in one single device
- Calculation of the mass flow from the measured variables volume flow and temperature in the integrated flow computer
- External pressure value read-in for superheated steam and gas applications (optional)
- External temperature value read-in for delta heat measurement (optional)

Table of contents

Function and system design	3	Certificates and approvals	31
Measuring principle	3	CE mark	31
Measuring system	5	C-tick	31
Input	5	Ex-approval	31
Measured variable	5	Pressure measuring device approval	31
Measuring range	5	Certification FOUNDATION Fieldbus	31
Output	6	Certification PROFIBUS PA	31
Output signal	7	Other standards and guidelines	32
Signal on alarm	9	Functional safety	32
Load	9	Ordering information	32
Low flow cut off	9	Accessories	33
Galvanic isolation	9	Documentation	33
Power supply	10	Registered trademarks	33
Electrical connection	10		
Wiring when using the HART input	10		
Wiring (remote version)	11		
Supply voltage	11		
Cable entry	11		
Power supply failure	11		
Performance characteristics	12		
Reference operating conditions	12		
Maximum measured error	12		
Repeatability	12		
Reaction time/step response time	12		
Influence of ambiente temperature	12		
Operating conditions: installation	13		
Installation instructions	13		
Inlet and outlet run	15		
Operating conditions: environment	17		
Ambient temperature range	17		
Storage temperature	17		
Degree of protection	17		
Vibration resistance	17		
Electromagnetic compatibility (EMC)	17		
Operating conditions: process	17		
Fluid temperature range	17		
Fluid pressure	18		
Pressure loss	20		
Mechanical construction	20		
Design, dimensions	20		
Weight	29		
Material	29		
Human interface	30		
Display elements	30		
Operating elements (HART)	30		
Remote operation	30		

Function and system design

Measuring principle

Vortex meters work on the principle of the Karman vortex street. When fluid flows past a bluff body, vortices are alternately formed on both sides with opposite directions of rotation. These vortices each generate a local low pressure. The pressure fluctuations are recorded by the sensor and converted to electrical pulses. The vortices develop very regularly within the permitted application limits of the device. Therefore, the frequency of vortex shedding is proportional to the volume flow.

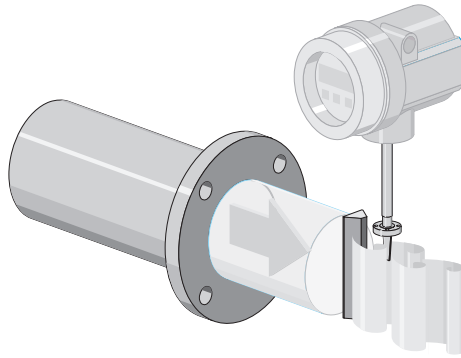

A0003938

The K-factor is used as the proportional constant:

$$\text{K-Factor} = \frac{\text{Pulses}}{\text{Unit Volume [dm}^3\text{]}}$$

A0003939-EN

Within the application limits of the device, the K-factor only depends on the geometry of the device. It is independent of the fluid velocity and the fluid properties viscosity and density. In this way, the K-factor is also independent of the type of matter that is to be measured, regardless of whether this is steam, gas or liquid. The primary measuring signal is already digital (frequency signal) and linear to the flow. After production, the K-factor is determined in the factory by means of calibration and is not subject to long-time or zero-point drift. The device does not contain any moving parts and does not require maintenance.

The capacitive sensor

The sensor of a vortex flowmeter has a major influence on the ability, robustness and reliability of the whole measuring system.

The robust DSC sensor - with an integrated temperature sensor (Pt 1000) with Prowirl 73 - is burst-tested and vibration and temperature-shock-tested (temperature shocks of 150 K/s).

The Prowirl uses the tried-and-tested capacitive measuring technology of Endress+Hauser applied in over 100,000 vortex measuring points worldwide.

The DSC sensor (Differential Switched Capacitance) patented by Endress+Hauser has complete mechanical balancing. It only reacts to the measured variable (vortex), not to vibrations. Even in the event of pipe vibrations, the smallest of flows can be reliably measured at low density thanks to the unimpaired sensitivity of the sensor.

Thus, the wide turndown is also maintained even in the event of harsh operating conditions. Vibrations up to 1 g, in frequencies up to 500 Hz in every axis (X, Y, Z), do not affect the flow measurement.

Thanks to its design, the capacitive sensor is also particularly mechanically resistant to temperature shocks and water hammer in steam lines.

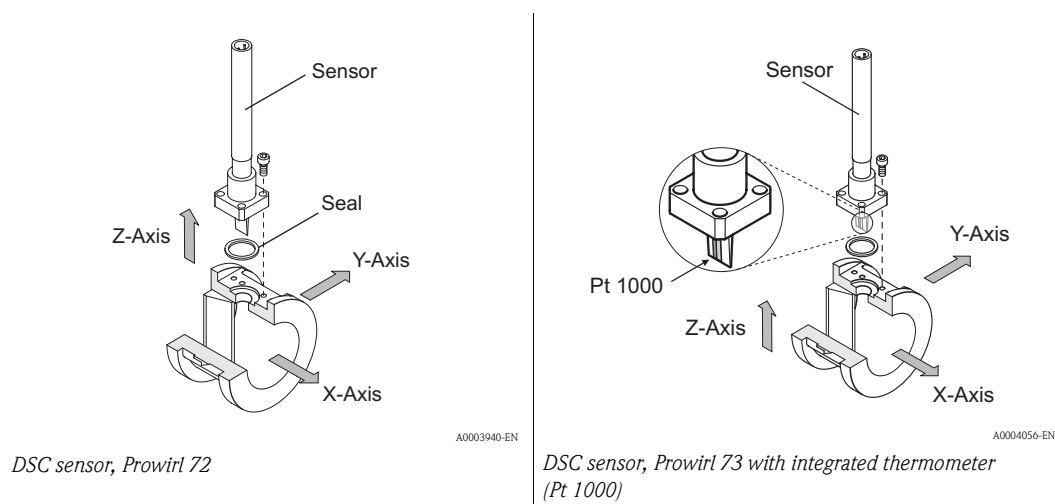

Temperature measurement (Prowirl 73)

In addition to the volume flow, the measuring device also measures the fluid temperature.

The temperature is measured by means of a Pt 1000 temperature sensor which is located in the paddle of the DSC sensor, i.e. directly in the fluid (Fig. Pt 1000).

Flow computer (Prowirl 73)

The electronics of the measuring device have an integral flow computer. With the aid of this flow computer other process variables can be calculated from the primary measured variables (volume flow and temperature), e.g.:

- The mass flow and heat flow of saturated steam and water in accordance with IAPWS-IF97/ASME
- The mass flow and heat flow of superheated steam (at constant pressure or pressure read in via HART/PROFIBUS PA/FOUNDATION Fieldbus) in accordance with IAPWS-IF97/ASME
- The mass flow and corrected volume flow of other gases (at a constant pressure or pressure read in via HART/PROFIBUS PA/FOUNDATION Fieldbus, e.g. compressed air or optional natural gas AGA NX-19)
- The mass flow of any liquid (linear equation)
- Delta heat between saturated steam and condensate (second temperature read in via HART) in accordance with IAPWS-IF97/ASME
- Delta heat between warm water and cold water (second temperature read in via HART) in accordance with IAPWS-IF97/ASME
- In saturated steam measurements, the pressure of the steam can also be calculated from the measured temperature and output in accordance with IAPWS-IF97/ASME

Diagnostic options (Prowirl 73)

Extensive diagnostic options, such as retracing fluid and ambient temperatures, extreme flows etc., are also optionally available for the measuring device.

Measuring system

The measuring system comprises a sensor and a transmitter.

Two versions are available:

- Compact version: sensor and transmitter form a mechanical unit.
- Remote version: sensor is mounted separate from the transmitter.

Sensor

- Prowirl F (flanged version)
- Prowirl W (wafer version)

Transmitter

- Prowirl 72
- Prowirl 73

Input

Measured variable**Prowirl 72**

- Volumetric flow (volume flow) is proportional to the frequency of vortex shedding after the bluff body.
- The volume flow or, if process conditions are constant, the mass flow or corrected volume flow can be output as the output variables.

Prowirl 73

- Volumetric flow (volume flow) is proportional to the frequency of vortex shedding after the bluff body.
- The temperature can be output directly and is used to calculate the mass flow for example.
- The measured process variables volume flow, temperature or the calculated process variables mass flow, heat flow or corrected volume flow can be output as the output variables.

Measuring range

The measuring range depends on the fluid and the nominal diameter.

Start of measuring range

Depends on the density and the Reynolds number ($Re_{\min} = 4,000$, $Re_{\text{linear}} = 20,000$).

The Reynolds number is dimensionless and is the ratio of inertial forces to viscous forces of the fluid. It is used for characterizing the flow. The Reynolds number is calculated as follows:

$$Re = \frac{4 \cdot Q \text{ [m}^3\text{/s]} \cdot \rho \text{ [kg/m}^3\text{]}}{\pi \cdot di \text{ [m]} \cdot \mu \text{ [Pa}\cdot\text{s]}}$$

Re = Reynolds number; Q = flow; di = internal diameter; μ = dynamic viscosity, ρ = density

A0003794

$$DN\ 15\dots25 \rightarrow v_{\min.} = \frac{6}{\sqrt{\rho \text{ [kg/m}^3\text{]}}} \text{ [m/s]} \quad DN\ 40\dots300 \rightarrow v_{\min.} = \frac{7}{\sqrt{\rho \text{ [kg/m}^3\text{]}}} \text{ [m/s]}$$

A0003239

Full scale value

- Gas/steam: $v_{\max} = 75$ m/s (DN 15: $v_{\max} = 46$ m/s)
- Liquids: $v_{\max} = 9$ m/s

Note!

By using the selection and planning program "Applicator", you can determine the exact values for the fluid you use. You can obtain the Applicator from your Endress+Hauser sales center or on the Internet under www.endress.com.

Measuring range for gases [m³/h or Nm³/h]

In the case of gases, the start of the measuring range depends on the density. With ideal gases, the density [ρ] or corrected density [ρ_N] can be calculated using the following formulae:

$$\rho \text{ [kg/m}^3\text{]} = \frac{\rho_N \text{ [kg/Nm}^3\text{]} \cdot P \text{ [bar abs]} \cdot 273.15 \text{ [K]}}{T \text{ [K]} \cdot 1.013 \text{ [bar abs]}} \quad \rho_N \text{ [kg/Nm}^3\text{]} = \frac{\rho \text{ [kg/m}^3\text{]} \cdot T \text{ [K]} \cdot 1.013 \text{ [bar abs]}}{P \text{ [bar abs]} \cdot 273.15 \text{ [K]}}$$

A0003946

The following formulae can be used to calculate the volume [Q] or corrected volume [Q_N] in the case of ideal gases:

$$Q \text{ [m}^3\text{/h]} = \frac{Q_N \text{ [Nm}^3\text{/h]} \cdot T \text{ [K]} \cdot 1.013 \text{ [bar abs]}}{P \text{ [bar abs]} \cdot 273.15 \text{ [K]}} \quad Q_N \text{ [Nm}^3\text{/h]} = \frac{Q \text{ [m}^3\text{/h]} \cdot P \text{ [bar abs]} \cdot 273.15 \text{ [K]}}{T \text{ [K]} \cdot 1.013 \text{ [bar abs]}}$$

A0003941

T = Operating temperature, *P* = operating pressure

Output

Prowirl 72

By means of the outputs in the 4...20mA/HART version of Prowirl 72, the volume flow and, if process conditions are constant, the calculated mass flow and corrected volume flow can be output via the current output and optionally via the pulse output or as a limit value via the status output.

Prowirl 73

By means of the outputs in the 4...20mA/HART version of Prowirl 73, the following measured variables can generally be output:

	Current output	Frequency output	Pulse output	Status output
Volume flow	If configured	If configured	If configured	Limit value*
Temperature	If configured	If configured	–	Limit value
Mass flow	If configured	If configured	If configured	Limit value*
Corrected volume flow	If configured	If configured	If configured	Limit value*
Heat flow (performance)	If configured	If configured	If configured	Limit value*
Saturation steam pressure (only for saturated steam)	If configured	If configured	If configured	Limit value*
Operating pressure (if read in externally)	If configured	If configured	If configured	Limit value*

* Limit value for flow or totalizer

If configured, the calculated measured variables density, specific enthalpy, saturation steam pressure (for saturated steam), Z-factor and flow velocity can also be shown on the local display for Prowirl 73.

Output signal

Prowirl 72

Current output:

- 4...20 mA with HART,
- Full scale value and time constant (0...100 s) can be set

Pulse/status output:

- Open collector, passive, galvanically isolated
 - Non-Ex, Ex d version:
 $U_{\max} = 36 \text{ V}$, with 15 mA current limiting, $R_i = 500 \Omega$
 - Ex i and Ex n version:
 $U_{\max} = 30 \text{ V}$, with 15 mA current limiting, $R_i = 500 \Omega$

The pulse/status output can be configured as:

- Pulse output:
 - Pulse value and polarity can be selected (5...2,000 ms)
 - Pulse width can be configured (0.005...2s)
 - Pulse frequency max. 100 Hz
- Status output:
 - Can be configured for error messages or flow limit values
- Vortex frequency:
 - Direct output of unscaled vortex pulses 0.5...2,850 Hz (e.g. for connecting to an RMC 621 flow computer)
 - Pulse ratio 1:1

PROFIBUS PA interface:

- PROFIBUS PA in accordance with EN 50170 Volume 2, IEC 61158-2 (MBP), galvanically isolated
- Current consumption = 16 mA
- Error current FDE (Fault Disconnection Electronic) = 0 mA
- Data transmission rate: supported baudrate = 31.25 kBit/s
- Signal encoding = Manchester II
- Function blocks: 1 x Analog Input, 1 x totalizer
- Output data: volume flow, calculated mass flow, corrected volume flow, totalizer
- Input data: positive zero return (ON/OFF), totalizer control
- Bus address can be set at the device via DIP switches

FOUNDATION Fieldbus interface:

- FOUNDATION Fieldbus H1, IEC 61158-2, galvanically isolated
 - Current consumption = 16 mA
 - Error current FDE (Fault Disconnection Electronic) = 0 mA
 - Data transmission rate: supported baudrate = 31.25 kBit/s
 - Signal encoding = Manchester II
 - Function blocks: 2 x Analog Input, 1 x Discrete Output
 - Output data: volume flow, calculated mass flow, corrected volume flow, totalizer
 - Input data: positive zero return (ON/OFF), totalizer reset
 - Link Master (LM) functionality is supported
-

Prowirl 73

Current output:

- 4...20 mA with HART,
- Full scale value and time constant (0...100 s) can be set

Frequency output, pulse/status output:

- Frequency output (optional): open collector, passive, galvanically isolated
 - Non-Ex, Ex d version:
 $U_{\max} = 36 \text{ V}$, with 15 mA current limiting, $R_i = 500 \Omega$
 - Ex i and Ex n version:
 $U_{\max} = 30 \text{ V}$, with 15 mA current limiting, $R_i = 500 \Omega$

The pulse/status output can be configured as:

- Frequency output:
 - End frequency 0...1,000 Hz ($f_{\max} = 1,250 \text{ Hz}$)
- Pulse output:
 - Pulse value and polarity can be selected (5...2,000 ms)
 - Pulse width can be configured (0.005...2s)
 - Pulse frequency max. 100 Hz
- Status output:
 - Can be configured for error messages or flow values, temperature values, pressure limit values
- Vortex frequency:
 - Direct output of unscaled vortex pulses 0.5...2,850 Hz
(e.g. for connecting to an RMC 621 flow computer)
 - Pulse ratio 1:1

PROFIBUS PA interface:

- PROFIBUS PA in accordance with EN 50170 Volume 2, IEC 61158-2 (MBP), galvanically isolated
- Current consumption = 16 mA
- Error current FDE (Fault Disconnection Electronic) = 0 mA
- Data transmission rate: supported baudrate = 31.25 kBit/s
- Signal encoding = Manchester II
- Function blocks: 4 x Analog Input, 2 x totalizer
- Output data: volume flow, mass flow, corrected volume flow, heat flow, temperature, density, specific enthalpy, calculated steam pressure (saturated steam), operating Z-factor, vortex frequency, electronics temperature, Reynolds number, velocity, totalizer
- Input data: positive zero return (ON/OFF), totalizer control, pressure, display value
- Bus address can be set at the device via DIP switches

FOUNDATION Fieldbus interface:

- FOUNDATION Fieldbus H1, IEC 61158-2, galvanically isolated
 - Current consumption = 16 mA
 - Error current FDE (Fault Disconnection Electronic) = 0 mA
 - Data transmission rate: supported baudrate = 31.25 kBit/s
 - Signal encoding = Manchester II
 - Function blocks: 6 x Analog Input, 1 x Discrete Output, 1 x Analog Output
 - Output data: volume flow, mass flow, corrected volume flow, heat flow, temperature, density, specific enthalpy, calculated steam pressure (saturated steam), operating Z-factor, vortex frequency, electronics temperature, Reynolds number, velocity, totalizer 1 + 2
 - Input data: positive zero return (ON/OFF), totalizer reset, pressure
 - Link Master (LM) functionality is supported
-

Signal on alarm

- Current output: error response can be selected (e.g. in accordance with NAMUR Recommendation NE 43)
 - Pulse output: error response can be selected
 - Status output: "not conducting" in event of fault (open circuit)
-

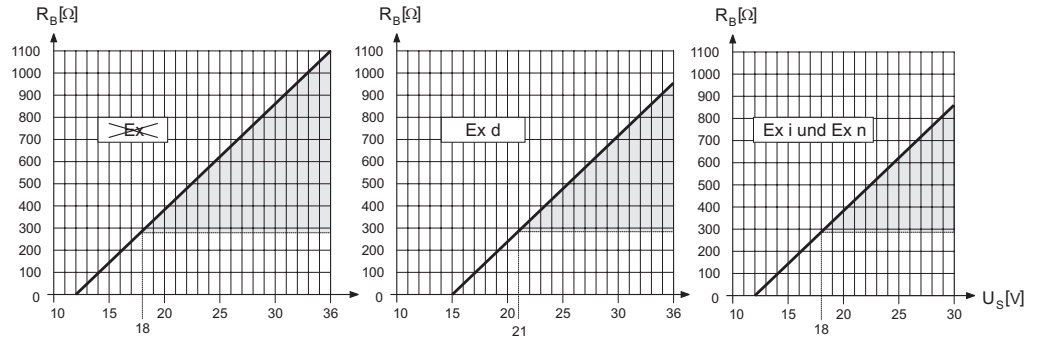
Load

A0001921

The area shaded gray refers to the permitted load (for HART: min. 250 Ω)

The load is calculated as follows:

$$R_B = \frac{(U_S - U_{Kl})}{(I_{max} - 10^{-3})} = \frac{(U_S - U_{Kl})}{0.022}$$

R_B Load, load resistance

U_S Supply voltage: non-Ex = 12...36 V DC; Ex d = 15...36 V DC; Ex i and Ex n = 12...30 V DC

U_{Kl} Terminal voltage: non-Ex = min. 12 V DC; Ex d = min. 15 V DC; Ex i and Ex n = min. 12 V DC

I_{max} Output current (22.6 mA)

Low flow cut off

Switch points for low flow cut off can be selected as required

Galvanic isolation

All electrical connections are galvanically isolated from one another.

Power supply

Electrical connection

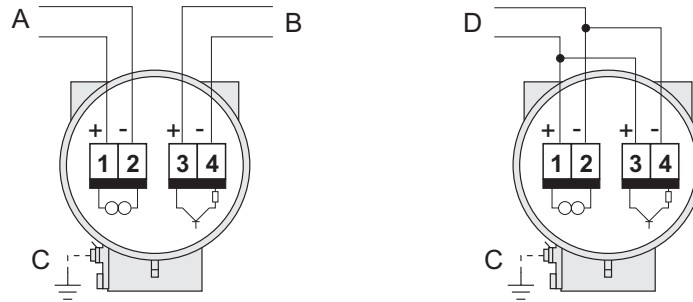

A0003392

- A – HART: power supply, current output
– PROFIBUS PA: 1 = PA+, 2 = PA–
– FOUNDATION Fieldbus: 1 = FF+, 2 = FF–
- B Optional frequency output (not for PROFIBUS PA and FOUNDATION Fieldbus), can also be operated as:
– Pulse or status output
– Only Prowirl 73: as a PFM output (pulse/frequency modulation) together with an RMC or RMS 621 flow computer
- C Ground terminal (relevant for remote version)
- D Only Prowirl 72: PFM (pulse-frequency modulation) wiring

Wiring when using the HART input

Process for reading in pressure, temperature or density with Prowirl 73:

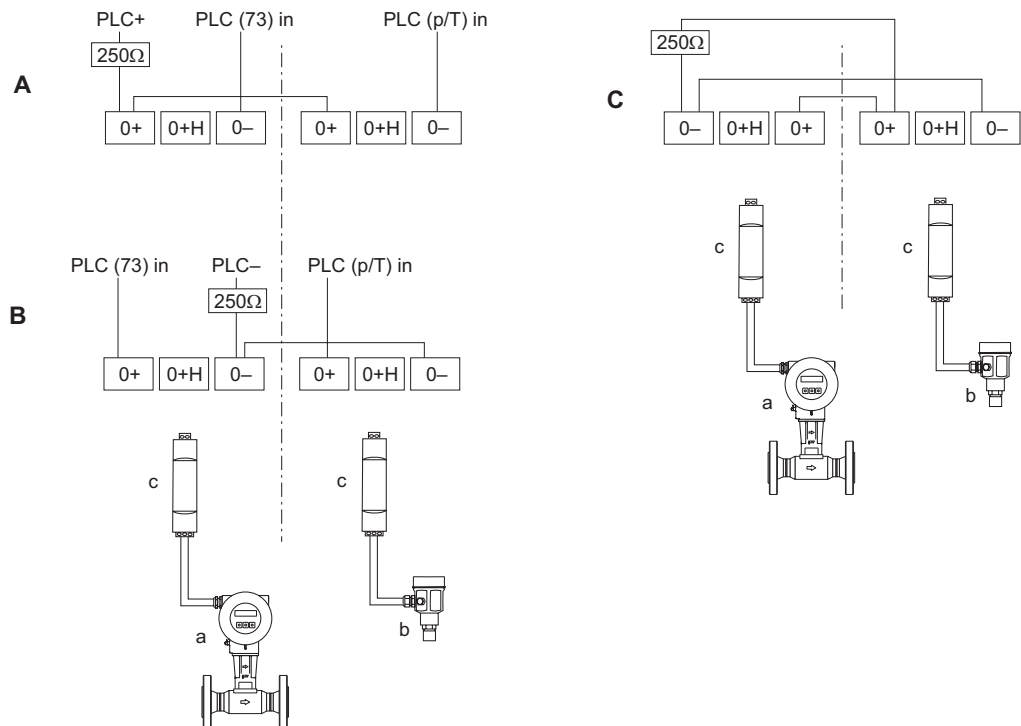

A0004215

- A Process control system with common “plus”
- B Process control system with common “minus”
- C Connection diagram without process control system
- a Prowirl 73
- b Cerabar-M or other HART-enabled **and** burst-enabled pressure, temperature or density transmitter
- c Active barrier preline RN221N

Wiring (remote version)

Note!

- The remote version must be grounded. In doing so, the sensor and transmitter must be connected to the same potential matching system.

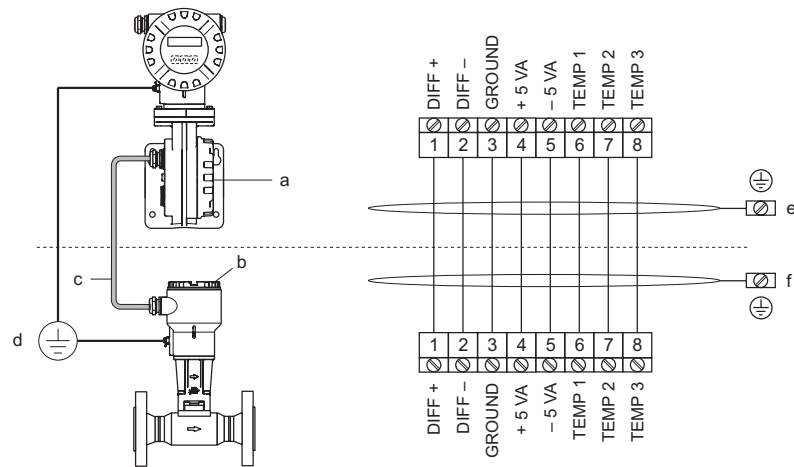

Connecting the remote version

a = Connection compartment cover (transmitter)

b = Connection compartment cover (sensor)

c = Connecting cable (signal cable)

d = Identical potential matching for sensor and transmitter

e = Connect shielding to ground terminal in transmitter housing and keep as short as possible

f = Connect shielding to ground terminal in connection housing

Wire colors (colour code according to DIN 47100):

Terminal number: 1 = white; 2 = brown; 3 = green; 4 = yellow, 5 = gray; 6 = pink; 7 = blue; 8 = red

A0001893

Supply voltage

HART:

- Non-Ex: 12...36 V DC (18...36 V DC)
- Ex i and Ex n: 12...30 V DC (18...30 V DC)
- Ex d: 15...36 V DC (21...36 V DC)

PROFIBUS PA and FOUNDATION Fieldbus:

- Non-Ex: 9...32 V DC
- Ex i and Ex n: 9...24 V DC
- Ex d: 9...32 V DC
- Current consumption → PROFIBUS PA: 16 mA, FOUNDATION Fieldbus: 16 mA

Cable entry

Power supply and signal cables (outputs):

- Cable entry M20 x 1.5 (8...11.5 mm)
- Thread for cable entry: ½" NPT, G ½", G ½" Shimada
- Fieldbus connector

Power supply failure

- Totalizer stops at the last value determined (can be configured)
- All settings are kept in the EEPROM
- Error messages (incl. value of operated hours counter) are stored

Performance characteristics

Reference operating conditions

Error limits following ISO/DIN 11631:
20...30 °C, 2...4 bar, calibration rig traceable to national calibration standards
Calibration with the process connection corresponding to the standard in question

Maximum measured error

Prowirl 72

- Liquid:
 - < 0.75% o.r. for Re > 20,000
 - < 0.75% o.f.s for Re between 4,000...20,000
 - Gas/steam:
 - < 1% o.r. for Re > 20,000
 - < 1% o.f.s for Re between 4,000...20,000
- o.r. = of reading, o.f.s = of full scale value, Re = Reynolds number

Prowirl 73

- Liquid (volume flow):
 - < 0.75% o.r. for Re > 20,000
 - < 0.75% o.f.s for Re between 4,000...20,000
 - Gas/steam (volume flow):
 - < 1% o.r. for Re > 20,000
 - < 1% o.f.s for Re between 4,000...20,000
 - Temperature:
 - < 1 °C (T > 100 °C, saturated steam);
 - rise time 50% (agitated under water, following IEC 60751): 8 s
 - Mass flow (saturated steam):
 - For flow velocities 20...50 m/s, T > 150 °C (423 K)
 - < 1.7% o.r. (2% o.r. for remote version) for Re > 20,000
 - < 1.7% o.f.s (2% o.f.s for remote version) for Re between 4,000...20,000
 - For flow velocities 10...70 m/s, T > 140 °C (413 K)
 - < 2% o.r. (2.3% o.r. for remote version) for Re > 20,000
 - < 2% o.f.s (2.3% o.f.s for remote version) for Re between 4,000...20,000
 - Mass flow (other media):
 - depending on the pressure value specified in the instrument functions and the chosen fluid
 - individual error observation must be carried out
- o.r. = of reading, o.f.s = of full scale value, Re = Reynolds number
-

Repeatability

±0.25% o.r. (of reading)

Reaction time/step response time

If all the configurable functions for filter times (flow damping, display damping, current output time constant, frequency output time constant, status output time constant) are set to 0, a reaction time/step response time of 200 ms must be reckoned with for vortex frequencies as of 10 Hz.
For other settings, a reaction time/step response time of 100 ms must always be added to the total filter reaction time for vortex frequencies as of 10 Hz.

Influence of ambiente temperature

Current output (additional error, in reference to the span of 16 mA):

- Zero point (4 mA):
 - average Tk: 0.05%/10 K, max. 0.6% over the entire temperature range –40 °C ... +80 °C
- Span (20 mA):
 - average Tk: 0.05%/10 K, max. 0.6% over the entire temperature range –40 °C ... +80 °C

Digital outputs (pulse output, PFM, HART, frequency output (Prowirl 73 only))

Due to the digital measuring signal (vortex pulse) and further digital processing, there is no interface-related error from changing ambient temperature.

Operating conditions: installation

Installation instructions

Vortex meters require a fully developed flow profile as a prerequisite for correct volume flow measurement. For this reason, please note the following points when installing the device:

Orientation

The device can generally be installed in any position in the piping.

In the case of liquids, there should be upward flow in vertical pipes to avoid partial pipe filling (see orientation A).

In the case of hot media (e.g. steam or fluid temperature $\geq 200\text{ °C}$), select orientation C or D so that the permitted ambient temperature of the electronics is not exceeded. Orientations B and D are recommended for very cold media (e.g. liquid nitrogen).

Orientations B, C and D are possible with horizontal installation.

The arrow indicated on the device must always point in the direction of flow in all orientations.

Caution!

- If fluid temperature is $\geq 200\text{ °C}$, orientation B is not permitted for the wafer version (Prowirl 72W, 73W) with a nominal diameter of DN 100 and DN 150.
- To guarantee the flow measurement of liquids, the measuring tube must always be completely full in pipes with vertical downward flow.

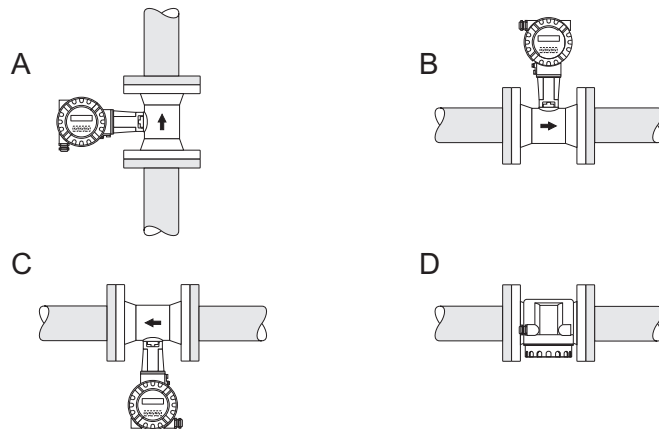

A0001869

Minimum spacing and cable length

To ensure problem-free access to the measuring device for service purposes, we recommend you observe the following dimensions:

- Minimum spacing in all directions = 100 mm (A)
- Necessary cable length $L + 150\text{ mm}$

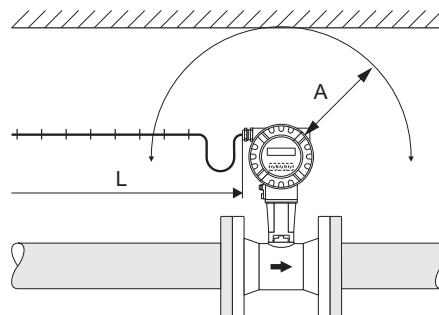

A0001870

Rotating the electronics housing and the display

The electronics housing can be rotated continuously 360 ° on the housing support. The display unit can be rotated in 45 ° stages. This means you can read off the display comfortably in all orientations.

Piping insulation

When insulating, please ensure that a sufficiently large area of the housing support is exposed. The uncovered part serves as a radiator and protects the electronics from overheating (or undercooling). The maximum insulation height permitted is illustrated in the diagrams. These apply equally to both the compact version and the sensor in the remote version.

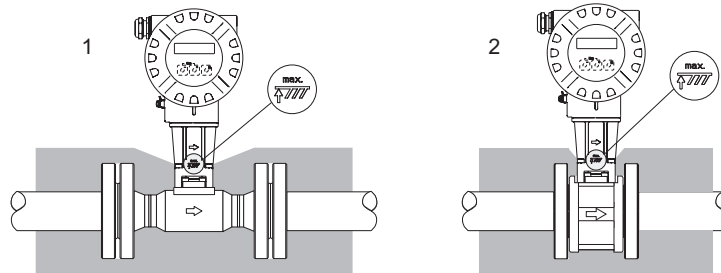

A0001868

- 1 = Flanged version
- 2 = Wafer version

Wafer version mounting set

The centering rings supplied are used to mount and center the wafer-style devices. A mounting set consisting of tie rods, seals, nuts and washers can be ordered separately.

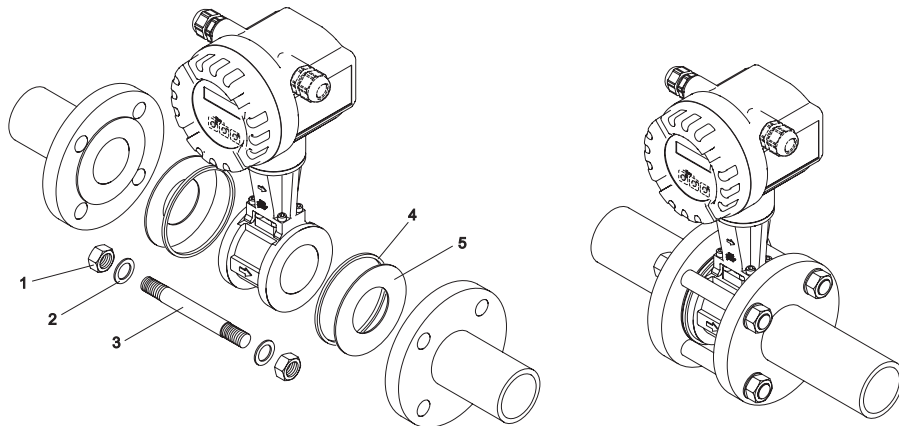

A0001868

Mounting wafer version

- 1 = Nut
- 2 = Washer
- 3 = Tie rod
- 4 = Centering ring (is supplied with the device)
- 5 = Seal

Inlet and outlet run

As a minimum, the inlet and outlet runs shown below must be observed to achieve the specified accuracy of the device. The longest inlet run shown must be observed if two or more flow disturbances are present.

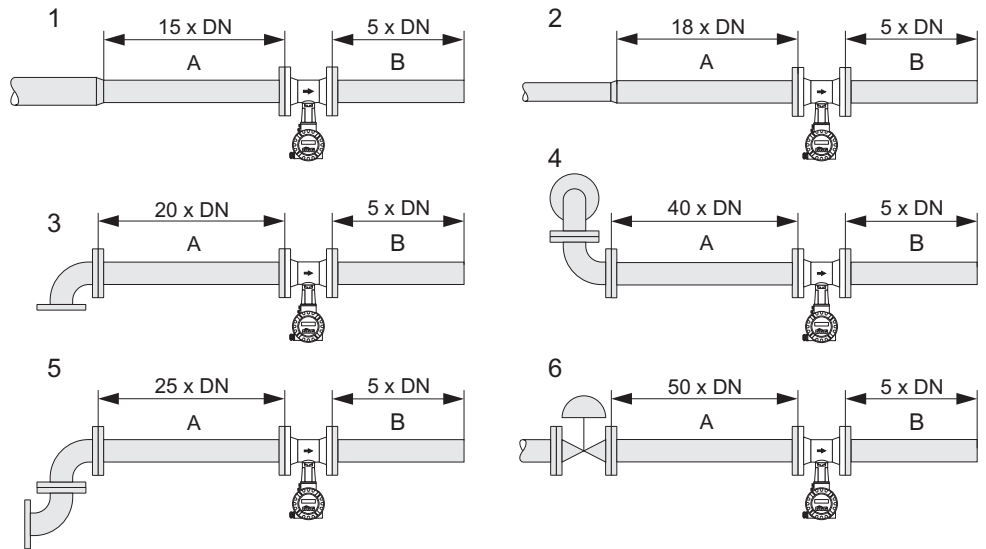

A0001867

Minimum inlet and outlet runs with various flow obstructions

- A = Inlet run
- B = Outlet run
- 1 = Reduction
- 2 = Extension
- 3 = 90° elbow or T-piece
- 4 = 2 x 90° elbow, -dimensional
- 5 = 2 x 90° elbow
- 6 = Control valve

Note!

A specially designed perforated plate flow conditioner can be installed if it is not possible to observe the inlet runs required (→ Page 16).

Outlet runs with pressure and temperature measuring points

If pressure and temperature measuring points are installed after the device, please ensure there is a large enough distance between the device and the measuring point so there are no negative effects on vortex formation in the sensor.

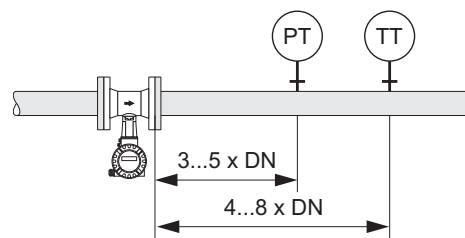

- PT = Pressure measuring point
- TT = Temperature measuring point

A0003780

Perforated plate flow conditioner

A specially designed perforated plate flow conditioner, available from Endress+Hauser, can be installed if it is not possible to observe the inlet runs required.

The flow conditioner is fitted between two piping flanges and centered with the mounting bolts. Generally, this reduces the inlet run required to 10 x DN with complete accuracy.

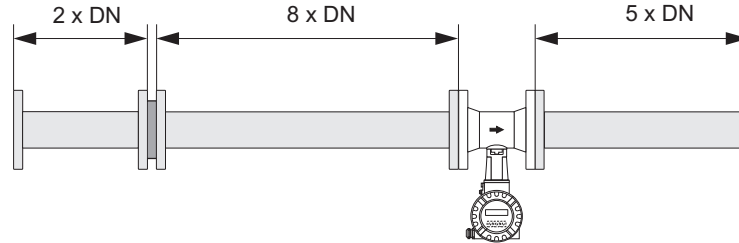

A0001887

The pressure loss for flow conditioners is calculated as follows:

$$\Delta p [\text{mbar}] = 0.0085 \cdot \rho [\text{kg/m}^3] \cdot v^2 [\text{m/s}]$$

Examples of pressure loss for flow conditioner

■ Example with steam

$p = 10 \text{ bar abs}$

$t = 240 \text{ }^\circ\text{C} \rightarrow \rho = 4.39 \text{ kg/m}^3$

$v = 40 \text{ m/s}$

$\Delta p = 0.0085 \cdot 4.39 \cdot 40^2 = 59.7 \text{ mbar}$

■ Example with H₂O condensate (80°C)

$\rho = 965 \text{ kg/m}^3$

$v = 2.5 \text{ m/s}$

$\Delta p = 0.0085 \cdot 965 \cdot 2.5^2 = 51.3 \text{ mbar}$

Installation of delta heat measurement (Prowirl 73 HART)

- The second temperature measurement takes place by means of a separate sensor and is read in via HART.
- Prowirl 73 generally has to be installed on the steam side for saturated steam delta heat measurement.
- For water-delta heat measurement, Prowirl 73 can be installed on both the cold side and the warm side.
- The inlet and outlet runs specified above must be observed.

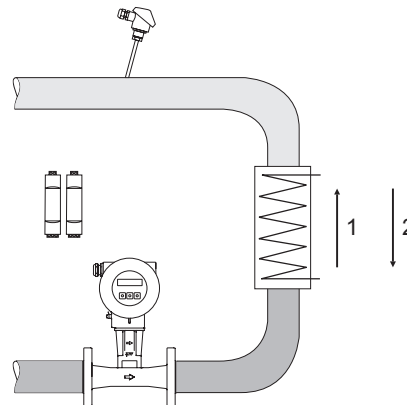

A0001809

Layout for delta heat measurement of saturated steam and water

Operating conditions: environment

Ambient temperature range	<ul style="list-style-type: none">■ Compact version: $-40\dots+70\text{ °C}$ (EEx-d version: $-40\dots+60\text{ °C}$; ATEX II 1/2 GD version/dust ignition-proof: $-20\dots+55\text{ °C}$) Display can be read between $-20\text{ °C}\dots+70\text{ °C}$■ Remote version: Sensor $-40\dots+85\text{ °C}$ (ATEX II 1/2 GD version/dust ignition-proof: $-20\dots+55\text{ °C}$) Transmitter $-40\dots+80\text{ °C}$ (EEx-d version: $-40\dots+60\text{ °C}$; ATEX II 1/2 GD version/dust ignition-proof: $-20\dots+55\text{ °C}$) Display can be read between $-20\text{ °C}\dots+70\text{ °C}$ <p>When mounting outside, protect from direct sunlight with a protective cover (order number 543199), especially in warmer climates with high ambient temperatures.</p>
Storage temperature	$-40\dots+80\text{ °C}$ (ATEX II 1/2 GD version/dust ignition-proof: $-20\dots+55\text{ °C}$)
Degree of protection	IP 67 (NEMA 4X) in accordance with EN 60529
Vibration resistance	Acceleration up to 1 g, 10...500 Hz, following IEC 60068-2-6
Electromagnetic compatibility (EMC)	To EN 61326/A1 and NAMUR Recommendation NE 21

Operating conditions: process

Fluid temperature range	Prowirl 72 <ul style="list-style-type: none">DSC standard sensor $-40\dots+260\text{ °C}$DSC high/low temperature sensor $-200\dots+400\text{ °C}$DSC sensor Inconel $-200\dots+400\text{ °C}$ (PN 63...160, Class 600, JIS 40K and Dualsens version)DSC sensor titanium Gr. 5 $-50\dots+400\text{ °C}$ (PN 250, Class 900...1500 and butt-weld version)DSC sensor Alloy C-22 $-200\dots+400\text{ °C}$■ Seal:<ul style="list-style-type: none">Graphite $-200\dots+400\text{ °C}$Viton $-15\dots+175\text{ °C}$Kalrez $-20\dots+275\text{ °C}$Gylon (PTFE) $-200\dots+260\text{ °C}$ Prowirl 73 <ul style="list-style-type: none">DSC standard sensor $-200\dots+400\text{ °C}$DSC sensor Inconel $-200\dots+400\text{ °C}$ (PN 63...160, Class 600, JIS 40K and Dualsens version in development)■ Seal:<ul style="list-style-type: none">Graphite $-200\dots+400\text{ °C}$Viton $-15\dots+175\text{ °C}$Kalrez $-20\dots+275\text{ °C}$Gylon (PTFE) $-200\dots+260\text{ °C}$
--------------------------------	--

Fluid pressure

Prowirl 72

Pressure-temperature curve to EN (DIN), stainless steel

PN 10...40 → Prowirl 72W and 72F

PN 63...250 → Prowirl 72F

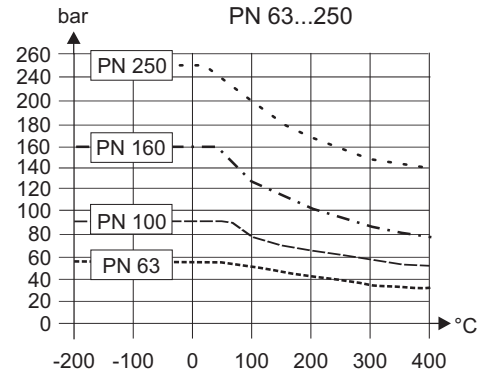
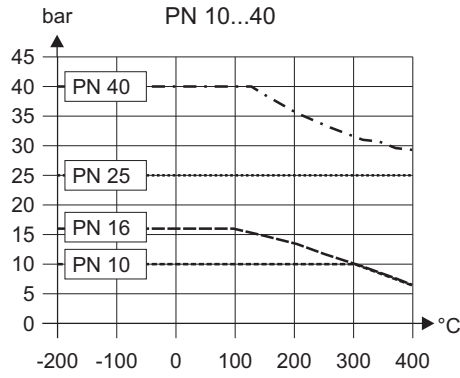

A0003238

Pressure-temperature curve to ANSI B16.5, stainless steel

ANSI B16.5:

Class 150...300 → Prowirl 72W and 72F

Class 600...1500 → Prowirl 72F

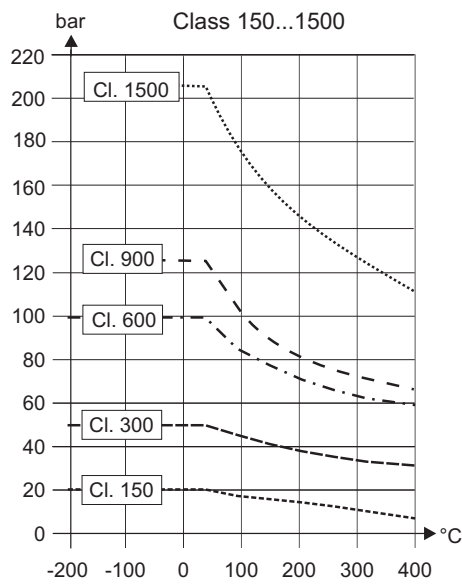

A0003402

Pressure-temperature curve to JIS B2238 and butt-weld version, stainless steel:

■ JIS B2238:

10...20K → Prowirl 72W and 72F
 40K → Prowirl 72F

■ Butt-weld version:

PN250, Cl 1500 → Prowirl 72F

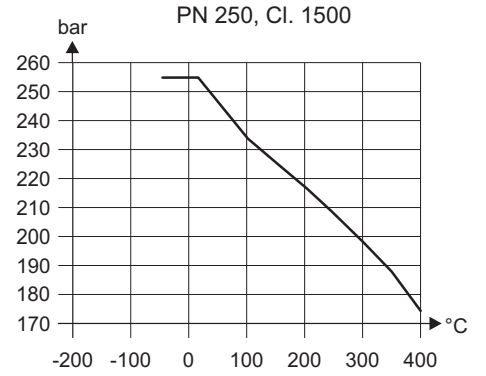
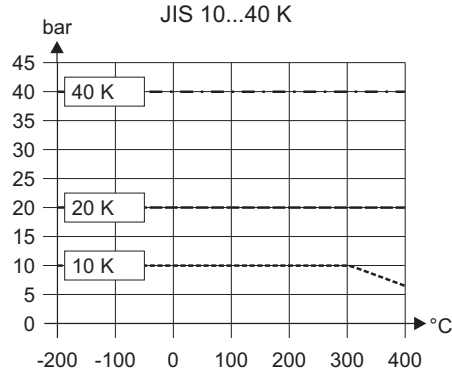

A0003404

Pressure-temperature curve to EN (DIN), ANSI B16.5 and JIS B2238, Alloy C-22

PN 16...40, Class 150...300, 10...20K → Prowirl 72F

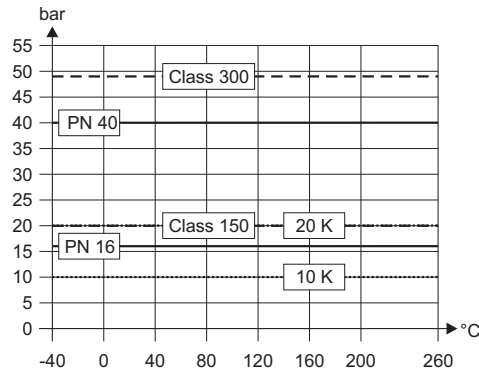

A0003395

Prowirl 73

Pressure-temperature curve to EN (DIN), stainless steel

PN 10...40 → Prowirl 73W and 73F

PN 63...160 → Prowirl 73F (in development)

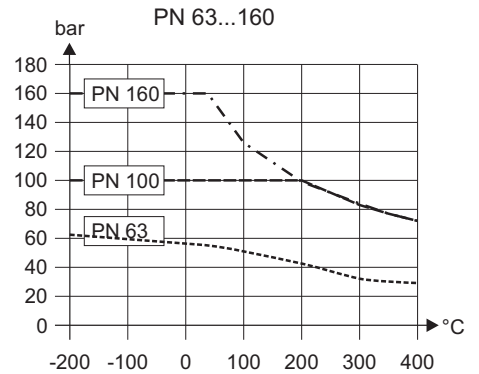
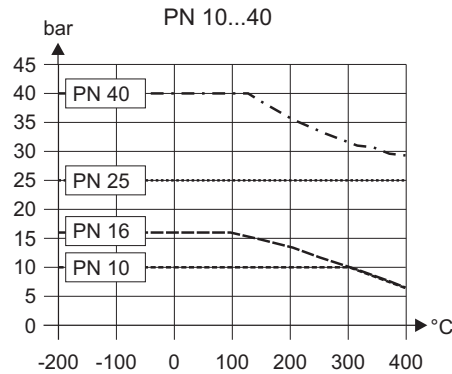

A0001922

Pressure-temperature curve to ANSI B16.5 and JIS B2238, stainless steel

ANSI B 16.5:

Class 150...300 → Prowirl 73W and 73F

Class 600 → Prowirl 73F (in development)

JIS B2238

10...20 K → Prowirl 73W and 73F

40 K → Prowirl 73F (in development)

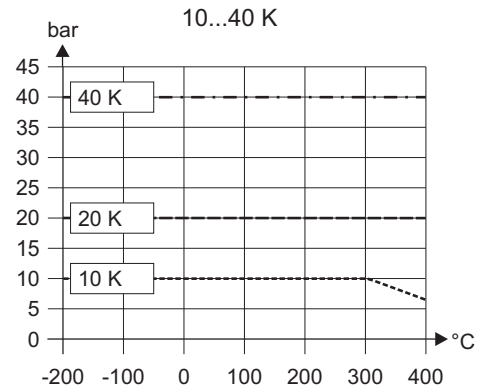
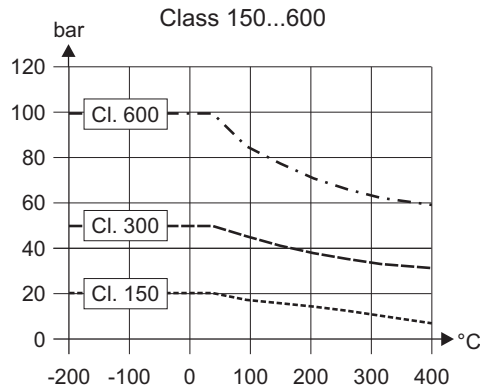

A0001923

Pressure loss

The pressure loss can be determined with the aid of Applicator. Applicator is software for selecting and planning flowmeters. The software is available both via the Internet (www.applicator.com) and on a CD-ROM for local PC installation.

Mechanical construction

Design, dimensions

Dimensions of transmitter, remote version

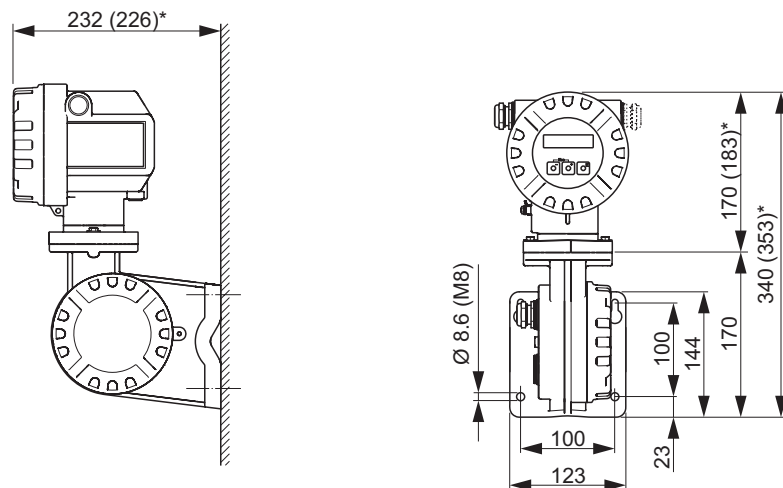

- * The following dimensions differ depending on the version:
- The dimension 232 mm changes to 226 mm in the blind version (without local operation).
 - The dimension 170 mm changes to 183 mm in the Ex d version.
 - The dimension 340 mm changes to 353 mm in the Ex d version.

A0003594

Dimensions of Prowirl 72W, 73 W

Wafer version for flanges to:

- EN 1092-1 (DIN 2501), PN 10...40
- ANSI B16.5, Class 150...300, Sch. 40
- JIS B2238, 10...20 K, Sch. 40

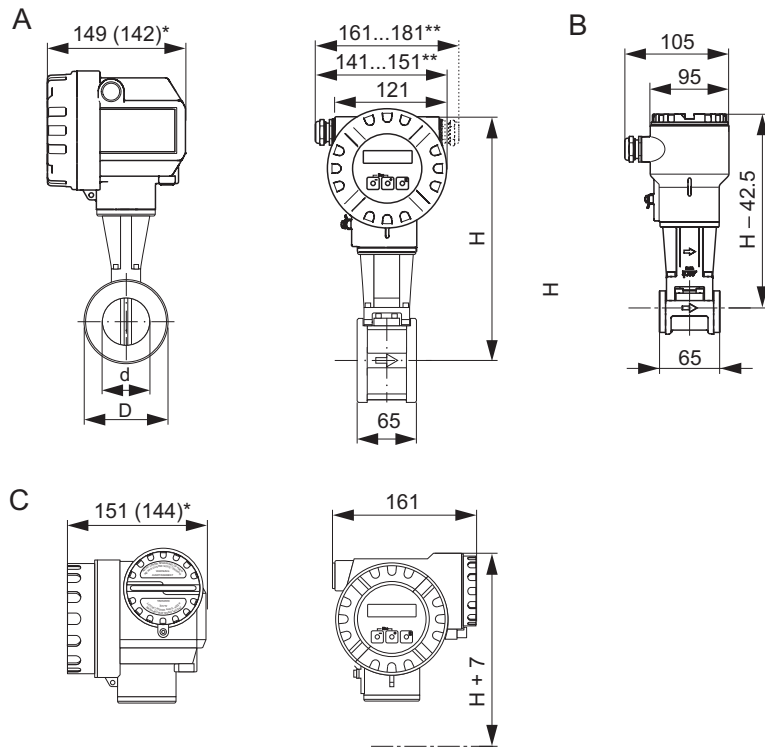

A = Standard as well as Ex i and Ex n version

B = Remote version

C = Ex d version (transmitter)

* The following dimensions change as follows in the blind version (without local operation):

- Standard as well as Ex i and Ex n version: the dimension 149 mm changes to 142 mm in the blind version.
- Ex d version: the dimension 151 mm changes to 144 mm in the blind version.

** The dimension depends on the cable gland used.

Note!

- In the following tables, dimension H increases by 29 mm for Prowirl 72 (high-temperature version and for the version with a DSC sensor made of Alloy C-22) and for Prowirl 73 (version with extended temperature range).
- The weight data refer to the compact version. The weight increases by 0.5 kg for Prowirl 72 (high-temperature version and for the version with a DSC sensor made of Alloy C-22) and for Prowirl 73 (version with extended temperature range).

Prowirl 72W, 73W						
DN		d	D	H	Weight	
DIN/JIS	ANSI	[mm]	[mm]	[mm]	[kg]	
15	½"	16.50	45.0	247	3.0	
25	1"	27.60	64.0	257	3.2	
40	1½"	42.00	82.0	265	3.8	
50	2"	53.50	92.0	272	4.1	
80	3"	80.25	127.0	286	5.5	
100 (DIN only)	–	104.75	157.2	299	6.5	
100 (JIS only)	4"	102.3	157.2	299	6.5	
150	6"	156.75	215.9	325	9.0	

Dimensions of Prowirl 72F, 73F

Flanged version to:

- EN 1092-1 (DIN 2501), Ra = 6.3...12.5 mm
- Raised face to:
 - EN 1092-1 Form B1 (DIN 2526 Form C), PN 10...40, Ra = 6.3...12.5 mm, optional with groove to EN1091-1 Form D (DIN 2512 Form N)
 - EN 1092-1 Form B2 (DIN 2526 Form E), PN 63...100, Ra = 1.6...3.2 mm^{1) 2)}
 - DIN 2526 Form E, PN 160...2503), Ra = 1.6...3.2 mm¹⁾
- ANSI B16.5, Class 150...15001) 2), Ra = 125...250 min²⁾
- JIS B2238, 10...40K1), Ra = 125...250 min

¹⁾ Prowirl 73F: PN63...160, Cl 600 and 40K in development

²⁾ Prowirl 73F: only Class 150...600

³⁾ Prowirl 73F: only PN 160

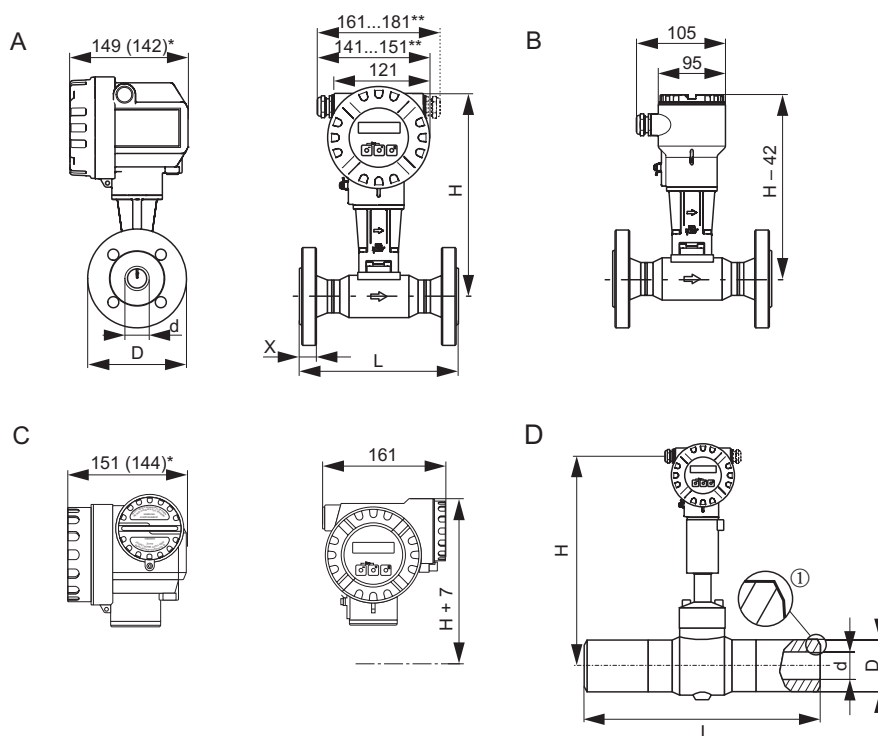

A0003537

A = Standard, Ex i and Ex n version

B = Remote version

C = Ex d version (transmitter)

D = Butt-weld version (only available for Prowirl 72)

* The following dimensions change as follows in the blind version (without local operation):

- Standard, Ex i and Ex n version: the dimension 149 mm changes to 142 mm in the blind version.
- Ex d version: the dimension 151 mm changes to 144 mm in the blind version.

** The dimension depends on the cable gland used.

① Groove type 22 in accordance with DIN 2559

Note!

- In the following tables, dimension H increases by 29 mm for Prowirl 72 (high-temperature version and for the version with a DSC sensor made of Alloy C-22) and for Prowirl 73 (pressure ratings up to PN 40, Cl. 300, 20K).
- The weight data refer to the compact version. The weight increases by 0.5 kg for Prowirl 72 (high-temperature version and for the version with a DSC sensor made of Alloy C-22 and for Prowirl 73 (pressure rating up to PN 40, Cl. 300, 20K).

Prowirl 72F, 73F to EN 1092-1 (DIN 2501)							
DN	Pressure rating	d [mm]	D [mm]	H [mm]	L [mm]	X [mm]	Weight [kg]
15	PN 40	17.3	95.0	248	200	16	5
	PN 160 ²⁾	17.3	105.0	288	200	23	7
	PN 250 ¹⁾	14.0	130.0	310	248	26	15
	Butt-weld ¹⁾	14.0	21.3	310	248	-	9
25	PN 40	28.5	115.0	255	200	18	7
	PN 100 ²⁾	28.5	140.0	295	200	27	11
	PN 160 ²⁾	27.9					
	PN 250 ¹⁾	24.3	15.0	310	248	28	16
	Butt-weld ¹⁾	24.3	26.5	310	248	-	9
40	PN 40	43.1	150.0	263	200	18	10
	PN 100 ²⁾	42.5	170.0	303	200	31	15
	PN 160 ²⁾	41.1					
	PN 250 ¹⁾	38.1	185.0	315	278	34	21
	Butt-weld ¹⁾	38.1	48.3	315	278	-	9
50	PN 40	54.5	165.0	270	200	20	12
	PN 63 ²⁾	54.5	180.0	310	200	33	17
	PN 100 ²⁾	53.9	195.0				19
	PN 160 ²⁾	52.3	200.0	306	288	38	23
	PN 250 ¹⁾	47.7					
	Butt-weld ¹⁾	47.7	60.3	306	288	-	9
80	PN 40	82.5	200.0	283	200	24	20
	PN 63 ²⁾	81.7	215.0	323	200	39	24
	PN 100 ²⁾	80.9	230.0				27
	PN 160 ²⁾	76.3	255.0	311	325	46	41
	PN 250 ¹⁾	73.7					
	Butt-weld ¹⁾	73.7	95.7	311	325	-	13
100	PN 16	107.1	220.0	295	250	20	27
	PN 40	107.1	235.0			24	
	PN 63 ²⁾	106.3	250.0	335	250	49	39
	PN 100 ²⁾	104.3	265.0				42
	PN 160 ²⁾	98.3	300.0	323	394	54	64
	PN 250 ¹⁾	97.3					
	Butt-weld ¹⁾	97.3	125.7	323	394	-	21
150	PN 16	159.3	285.0	319	300	22	51
	PN 40	159.3	300.0			28	
	PN 63 ²⁾	157.1	345.0	359	300	64	86
	PN 100 ²⁾	154.1	355.0				88
	PN 160 ²⁾	146.3	390.0	339	566	68	152
	PN 250 ¹⁾	131.8					
	Butt-weld ¹⁾	131.8	168.3	339	566	-	53
200	PN 10	207.3	340.0	348	300	42	63
	PN 16	207.3	340.0				62
	PN 25	206.5	360.0				68
	PN 40	206.5	375.0				72
250	PN 10	260.4	395.0	375	380	48	88
	PN 16	260.4	405.0				92
	PN 25	258.8	425.0				100
	PN 40	258.8	450.0				111
300	PN 10	309.7	445.0	398	450	51	121
	PN 16	309.7	460.0				129
	PN 25	307.9	485.0				140
	PN 40	307.9	515.0				158

¹⁾ In contrast to the other versions, devices have a sensor in the bluff body.

Only available for 72F.

²⁾ Pressure ratings are in development for Prowirl 73.

Prowirl 72F, 73F to ANSI B16.5								
DN	Pressure rating		d [mm]	D [mm]	H [mm]	L [mm]	X [mm]	Weight [kg]
½"	Schedule 40	Cl. 150	15.7	88.9	248	200	11.2	5
		Cl. 300	15.7	95.0			14.2	
	Schedule 80	Cl. 150	13.9	88.9			11.2	
		Cl. 300	13.9	95.0			14.2	
		Cl. 600 ²⁾	13.9	95.3	288	200	23	6
		Cl. 1500 ¹⁾	14.0	120.6	310	262	22.3	13
Butt-weld ¹⁾	14.0	21.3	310	248	-	9		
1"	Schedule 40	Cl. 150	26.7	107.9	255	200	15.7	7
		Cl. 300	26.7	123.8			19.1	
	Schedule 80	Cl. 150	24.3	107.9			15.7	
		Cl. 300	24.3	123.8			19.1	
		Cl. 600 ²⁾	24.3	124.0	295	200	27	9
		Cl. 1500 ¹⁾	24.3	149.3	310	287.7	28.4	17
Butt-weld ¹⁾	24.3	33.4	310	248	-	9		
1½"	Schedule 40	Cl. 150	40.9	127.0	263	200	17.5	10
		Cl. 300	40.9	155.6			20.6	
	Schedule 80	Cl. 150	38.1	127.0			17.5	
		Cl. 300	38.1	155.6			20.6	
		Cl. 600 ²⁾	38.1	155.4	303	200	31	13
		Cl. 1500 ¹⁾	38.1	177.8	315	305.8	31.7	20
Butt-weld ¹⁾	38.1	48.3	315	278	-	9		
2"	Schedule 40	Cl. 150	52.6	152.4	270	200	19.1	12
		Cl. 300	52.6	165.0			22.4	
	Schedule 80	Cl. 150	49.2	152.4			19.1	
		Cl. 300	49.2	165.0			22.4	
		Cl. 600 ²⁾	49.2	165.1	310	200	33	14
		Cl. 1500 ¹⁾	47.7	215.9	306	344	38.1	30
Butt-weld ¹⁾	47.7	60.3	306	288	-	9		
3"	Schedule 40	Cl. 150	78.0	190.5	283	200	23.9	20
		Cl. 300	78.0	210.0			28.4	
	Schedule 80	Cl. 150	73.7	190.5			23.9	
		Cl. 300	73.7	210.0			28.4	
		Cl. 600 ²⁾	73.7	209.6	323	200	39	22
		Cl. 900 ¹⁾	73.7	241.3	311	349	38.1	37
Cl. 1500 ¹⁾	73.7	266.7	311	380.4	47.7	49		
Butt-weld ¹⁾	73.7	95.7	311	325	-	13		
4"	Schedule 40	Cl. 150	102.4	228.6	295	250	24.5	27
		Cl. 300	102.4	254.0			31.8	
	Schedule 80	Cl. 150	97.0	228.6			24.5	
		Cl. 300	97.0	254.0			31.8	
		Cl. 600 ²⁾	97.0	273.1	335	250	49	43
		Cl. 900 ¹⁾	97.3	292.1	323	408	44.4	57
Cl. 1500 ¹⁾	97.3	311.1	323	427	53.8	71		
Butt-weld ¹⁾	97.3	125.7	323	394	-	21		
6"	Schedule 40	Cl. 150	154.2	279.4	319	300	25.4	51
		Cl. 300	154.2	317.5			36.6	
	Schedule 80	Cl. 150	146.3	279.4			25.4	
		Cl. 300	146.3	317.5			36.6	
		Cl. 600 ²⁾	146.3	355.6	359	300	64	87
		Cl. 900 ¹⁾	131.8	381.0	339	538	55.6	131
Cl. 1500 ¹⁾	131.8	393.7	339	602	82.5	173		
Butt-weld ¹⁾	131.8	168.3	339	566	-	53		
8"	Schedule 40	Cl. 150	202.7	342.9	348	300	42	64
		Cl. 300	202.7	381.0				76

Prowirl 72F, 73F to ANSI B16.5								
DN	Pressure rating		d [mm]	D [mm]	H [mm]	L [mm]	X [mm]	Weight [kg]
10"	Schedule 40	Cl. 150	254.5	406.4	375	380	48	92
		Cl. 300	254.5	444.5				109
12"	Schedule 40	Cl. 150	304.8	482.6	398	450	60	143
		Cl. 300	304.8	520.7				162

¹⁾ In contrast to the other versions, devices have a sensor in the bluff body.

Only available for 72F.

²⁾ Pressure ratings are in development for Prowirl 73.

Prowirl 72F, 73F to JIS B2238								
DN	Pressure rating		d [mm]	D [mm]	H [mm]	L [mm]	X [mm]	Weight [kg]
15	Schedule 40	20K	16.1	95.0	248	200	14	5
		20K	13.9	95.0			14	
	Schedule 80	40K ¹⁾	13.9	115.0	288	200	23	8
25	Schedule 40	20K	27.2	125.0	255	200	16	7
		20K	24.3	125.0			16	
	Schedule 80	40K ¹⁾	24.3	130.0	295	200	27	10
40	Schedule 40	20K	41.2	140.0	263	200	18	10
		20K	38.1	140.0			18	
	Schedule 80	40K ¹⁾	38.1	160.0	303	200	31	14
50	Schedule 40	10K	52.7	155.0	270	200	16	12
		20K	52.7	155.0			18	
	Schedule 80	10K	49.2	155.0			16	
		20K	49.2	155.0			18	
		40K ¹⁾	49.2	165.0			310	
80	Schedule 40	10K	78.1	185.0	283	200	18	20
		20K	78.1	200.0			22	
	Schedule 80	10K	73.7	185.0			18	
		20K	73.7	200.0			22	
		40K ¹⁾	73.7	210.0			323	
100	Schedule 40	10K	102.3	210.0	295	250	18	27
		20K	102.3	225.0			24	
	Schedule 80	10K	97.0	210.0			18	
		20K	97.0	225.0			24	
		40K ¹⁾	97.0	240.0			335	
150	Schedule 40	10K	151.0	280.0	319	300	22	51
		20K	151.0	305.0			28	
	Schedule 80	10K	146.3	280.0			22	
		20K	146.3	305.0			28	
		40K ¹⁾	146.6	325.0			359	
200	Schedule 40	10K	202.7	330.0	348	300	42	58
		20K	202.7	350.0			64	
250	Schedule 40	10K	254.5	400.0	375	380	48	90
		20K	254.5	430.0				104
300	Schedule 40	10K	304.8	445.0	398	450	51	119
		20K	304.8	480.0				134

¹⁾ Pressure rating 40 K for Prowirl 73 in development

Dimensions of Prowirl 72F, Dualsens version

Flanged version to:

- EN 1092-1 (DIN 2501), Ra = 6.3...12.5 mm
- Raised face to:
 - EN 1092-1 Form B1 (DIN 2526 Form C), PN 10...40, Ra = 6.3...12.5 mm, optional with groove to EN1091-1 Form D (DIN 2512 Form N)
 - EN 1092-1 Form B2 (DIN 2526 Form E), PN 63...100, Ra = 1.6...3.2 mm^{1) 2)}
 - DIN 2526 Form E, PN 160...2503), Ra = 1.6...3.2 mm¹⁾
- ANSI B16.5, Class 150...15001) 2), Ra = 125...250 min²⁾
- JIS B2238, 10...40K1), Ra = 125...250 min

1) Prowirl 73F: PN63...160, Cl 600 and 40K in development

2) Prowirl 73F: only Class 150...600

3) Prowirl 73F: only PN 160

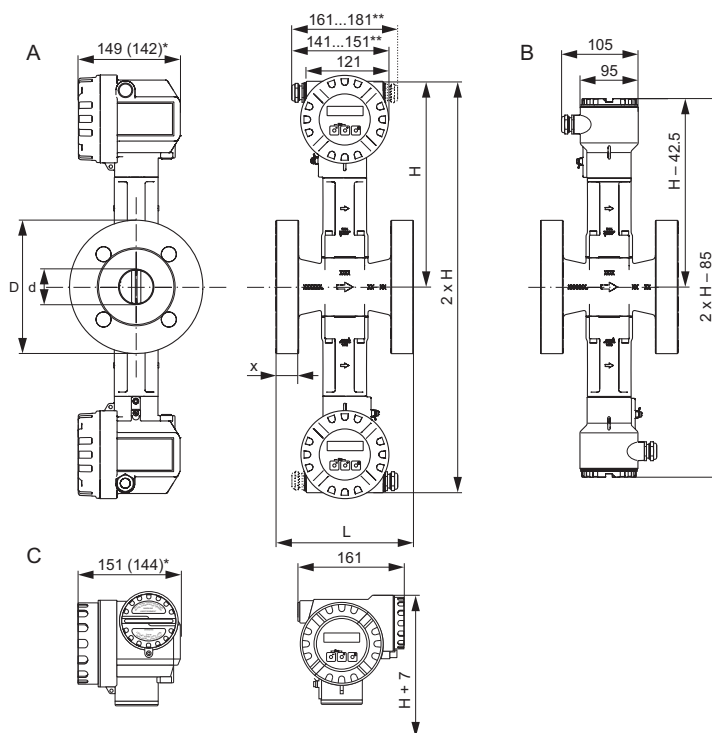

A = Standard, Ex i and Ex n version

B = Remote version

C = Ex d version (transmitter)

* The following dimensions change as follows in the blind version (without local operation):

- Standard, Ex i and Ex n version: the dimension 149 mm changes to 142 mm in the blind version.
- Ex d version: the dimension 151 mm changes to 144 mm in the blind version.

** The dimension depends on the cable gland used.

Note!

The weight data refer to the compact version.

Prowirl 72F Dualsens version to EN 1092-1 (DIN 2501)							
DN DIN/JIS	Pressure rating	d [mm]	D [mm]	H [mm]	L [mm]	X [mm]	Weight [kg]
40	PN 40	43.1	150.0	303	200	31	16
	PN 100	42.5	170.0				18
	PN 160	41.1	170.0				18
50	PN 40	54.5	165.0	310	200	33	18
	PN 63	54.5	180.0				20
	PN 100	53.9	195.0				22
	PN 160	52.3	195.0				22
80	PN 40	82.5	200.0	323	200	39	25
	PN 63	81.7	215.0				27
	PN 100	80.9	230.0				30
	PN 160	76.3	230.0				30
100	PN 16	107.1	220.0	335	250	49	42
	PN 40	107.1	235.0				42
	PN 63	106.3	250.0				45
	PN 100	104.3	265.0				45
	PN 160	98.3	265.0				45
150	PN 16	159.3	285.0	359	300	64	80
	PN 40	159.3	300.0				80
	PN 63	157.1	345.0				89
	PN 100	154.1	355.0				91
	PN 160	146.3	355.0				91

Prowirl 72F Dualsens version to ANSI B16.5								
DN ANSI	Pressure rating		d [mm]	D [mm]	H [mm]	L [mm]	X [mm]	Weight [kg]
1½"	Schedule 40	Cl. 150	40.9	127.0	303	200	31	16
		Cl. 300	40.9	155.6				
	Schedule 80	Cl. 150	38.1	127.0				
		Cl. 300	38.1	155.6				
2"	Schedule 40	Cl. 150	52.6	152.4	310	200	33	18
		Cl. 300	52.6	165.0				
	Schedule 80	Cl. 150	49.2	152.4				
		Cl. 300	49.2	165.0				
		Cl. 600	49.2	165.1				
3"	Schedule 40	Cl. 150	78.0	190.5	323	200	39	25
		Cl. 300	78.0	210.0				
	Schedule 80	Cl. 150	73.7	190.5				
		Cl. 300	73.7	210.0				
		Cl. 600	73.7	209.6				
4"	Schedule 40	Cl. 150	102.4	228.6	335	250	49	42
		Cl. 300	102.4	254.0				
	Schedule 80	Cl. 150	97.0	228.6				
		Cl. 300	97.0	254.0				
		Cl. 600	97.0	273.1				
6"	Schedule 40	Cl. 150	154.2	279.4	359	300	64	80
		Cl. 300	154.2	317.5				
	Schedule 80	Cl. 150	146.3	279.4				
		Cl. 300	146.3	317.5				
		Cl. 600	146.3	355.6				

Prowirl 72F Dualsens version to JIS B2238								
DN DIN/JIS	Pressure rating		d [mm]	D [mm]	H [mm]	L [mm]	X [mm]	Weight [kg]
40	Schedule 40	20K	41.2	140.0	303	200	31	16
	Schedule 80	20K	38.1	140.0				17
		40K	38.1	160.0				
50	Schedule 40	10K	52.7	155.0	310	200	33	18
		20K	52.7	155.0				
	Schedule 80	10K	49.2	155.0				
		20K	49.2	155.0				
		40K	49.2	165.0				
80	Schedule 40	10K	78.1	185.0	323	200	39	25
		20K	78.1	200.0				
	Schedule 80	10K	73.7	185.0				
		20K	73.7	200.0				
		40K	73.7	210.0				
100	Schedule 40	10K	102.3	210.0	335	250	49	42
		20K	102.3	225.0				
	Schedule 80	10K	97.0	210.0				
		20K	97.0	225.0				
		40K	97.0	240.0				
150	Schedule 40	10K	151.0	280.0	359	300	64	80
		20K	151.0	305.0				
	Schedule 80	10K	146.3	280.0				
		20K	146.3	305.0				
		40K	146.6	325.0				

Dimensions of flow conditioner (accessory)

Dimensions to:

- EN 1092-1 (DIN 2501)
- ANSI B16.5
- JIS B2238

Material 1.4435 (316L), in conformity with NACE MR 0175 and MR 0103

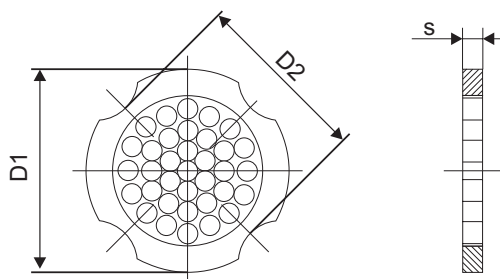

D1: The flow conditioner is fitted at the external diameter between the bolts.

D2: The flow conditioner is fitted at the indentations between the bolts.

A0001941

Flow conditioner to EN (DIN) / ANSI / JIS											
DN		15 / ½"	25 / 1"	40 / 1½"	50 / 2"	80 / 3"	100 / 4"	150 / 6"	200 / 8"	250 / 10"	300 / 12"
s [mm]		2.0	3.5	5.3	6.8	10.1	13.3	20.0	26.3	33.0	39.6
EN (DIN) Weight in [kg]	PN 10	0.04	0.12	0.30	0.50	1.40	2.40	6.30	11.5	25.7	36.4
	PN 16	0.04	0.12	0.30	0.50	1.40	2.40	6.30	12.3	25.7	36.4
	PN 25	0.04	0.12	0.30	0.50	1.40	2.40	7.80	12.3	25.7	36.4
	PN 40	0.04	0.12	0.30	0.50	1.40	2.40	7.80	15.9	27.5	44.7
	PN 63	0.05	0.15	0.40	0.60	1.40	2.40	7.80	15.9	27.5	44.7
ANSI Weight in [kg]	Cl. 150	0.03	0.12	0.30	0.50	1.20	2.70	6.30	12.3	25.7	36.4
	Cl. 300	0.04	0.12	0.30	0.50	1.40	2.70	7.80	15.8	27.5	44.6
JIS Weight in [kg]	10K	0.06	0.14	0.31	0.47	1.1	1.8	4.5	9.2	15.8	26.5
	20K	0.06	0.14	0.31	0.47	1.1	1.8	5.5	9.2	19.1	26.5
	40K	0.06	0.14	0.31	0.5	1.3	2.1	6.2	-	-	-

Weight

- Weight of Prowirl 72W, 73W → see dimension table on Page 21.
- Weight of Prowirl 72 F, 73 F → see dimension tables on Page 22 ff.
- Weight of flow conditioner to EN (DIN) / ANSI / JIS → see dimension table on Page 29.

Material

Transmitter housing

- Powder-coated die-cast aluminum AlSi10Mg
 - in accordance with EN 1706/EN AC-43400 (EEx-d/XP version: cast aluminum EN 1706/EN AC-43000)

Sensor

- Flanged version
 - Stainless steel, A351-CF3M (1.4404), in conformity with NACE MR 0175 and MR0103
 - Pressure ratings PN 250, Cl 900...1500 and butt-weld version (only for Prowirl 72) 1.4571 (316Ti; UNS S31635); in conformity with NACE MR0175 and MR0103
- Alloy C-22 version (only for Prowirl 72)
 - Alloy C-22 2.4602 (A 494-CX2MW/N 26022); in conformity with NACE MR0175 and MR0103
- Wafer version
 - Stainless steel, A351-CF3M (1.4404), in conformity with NACE MR 0175 and MR0103

Flanges

- EN (DIN)
 - Stainless steel, 316/316L/1.4404, in conformity with NACE MR 0175 and MR 0103
 - DN 15...150 with pressure ratings PN 63-160 (in development for Prowirl 73) and nominal diameters DN 200-300: fully cast construction A351-CF3M (1.4404); in conformity with NACE MR 0175 and MR0103
 - Pressure rating PN 250 (only for Prowirl 72) 1.4571 (316Ti, UNS S31635); in conformity with NACE MR 0175 and MR 0103
- ANSI and JIS
 - Stainless steel, 316/316L, in conformity with NACE MR 0175 and MR0103
 - ½"...6" with pressure ratings Cl 600 (in development for Prowirl 73), DN 15...150 with pressure rating 40 K, (in development for Prowirl 73), nominal diameters 8"-12" and DN 200-300: fully cast construction A351-CF3M; in conformity with NACE MR 0175 and MR0103
- Pressure ratings Cl 900...1500: 316/316L; in conformity with NACE MR0175 and MR0103 (only Prowirl 72)
- Alloy C-22 version (EN/DIN/ANSI/JIS, only Prowirl 72)
 - Alloy C-22 2.4602 (A 494-CX2MW/N 26022); in conformity with NACE MR 0175 and MR 0103

DSC sensor (Differential Switched Capacitor; capacitive sensor)

- Wetted parts (marked as "wet" on the DSC sensor flange):
 - Standard for pressure ratings up to PN 40, Cl 300, JIS 40 K (apart from Dualsens version): Stainless steel 1.4435 (316L), in conformity with NACE MR 0175 and MR 0103
 - Pressure ratings PN 63...160, Cl 600, 40 K and Dualsens version (in development for Prowirl 73): Inconel 2.4668/N 07718 (B637) (Inconel 718); in conformity with NACE MR 0175 and MR 0103
 - Pressure ratings PN 250, Cl 900...1500 and butt-weld version (only for Prowirl 72): titanium Gr. 5 (B-348; UNS R50250; 3.7165)
 - Alloy C-22 sensor (only for Prowirl 72): Alloy C-22, 2.4602/N 06022; in conformity with NACE MR 0175 and MR 0103

Non-wetted parts

- Non-wetted parts:
 - Stainless steel 1.4301 (304)

Support

- Support:
 - Stainless steel, 1.4308 (CF8)
 - Pressure ratings PN 250, Cl 900...1500 and butt-weld version (only for Prowirl 72): 1.4305 (303)

Seals

- Graphite (Grafoil)
- Viton
- Kalrez 6375
- Gylon (PTFE) 3504

Human interface

Display elements

Liquid crystal display, double-spaced, plain text display, 16 characters per line
Display can be configured individually, e.g. for measured variables and status values, totalizers

Operating elements (HART)

Local operation with three keys (◀, □, ▶)
Quick Setup for quick commissioning
Operating elements accessible also in Ex-zones

Remote operation

Remote operation possible via:

- HART
- PROFIBUS PA
- FOUNDATION Fieldbus
- Endress+Hauser Service Protocol

Certificates and approvals

CE mark	The device is in conformity with the statutory requirements of the EC Directives. Endress+Hauser confirms successful testing of the device by affixing the CE mark.
C-tick	The measuring system is in conformity with the EMC requirements of the Australian Communications Authority (ACA).
Ex-approval	<ul style="list-style-type: none">■ Ex i and Ex n:<ul style="list-style-type: none">– ATEX/CENELEC<ul style="list-style-type: none">II1/2G, EEx ia IIC T1...T6 (T1...T4 for PROFIBUS PA and FOUNDATION Fieldbus)II1/2GD, EEx ia IIC T1...T6 (T1...T4 for PROFIBUS PA and FOUNDATION Fieldbus)II1G, EEx ia IIC T1...T6 (T1...T4 for PROFIBUS PA and FOUNDATION Fieldbus)II2G, EEx ia IIC T1...T6 (T1...T4 for PROFIBUS PA and FOUNDATION Fieldbus)II3G, EEx nA IIC T1...T6 X (T1...T4 X for PROFIBUS PA and FOUNDATION Fieldbus)– FM<ul style="list-style-type: none">Class I/II/III Div. 1/2, Group A...G; Class I Zone 0, Group IIC– CSA<ul style="list-style-type: none">Class I/II/III Div. 1/2, Group A...G; Class I Zone 0, Group IICClass II Div. 1, Group E...GClass III■ Ex d:<ul style="list-style-type: none">– ATEX/CENELEC<ul style="list-style-type: none">II1/2G, EEx d [ia] IIC T1...T6 (T1...T4 for PROFIBUS PA and FOUNDATION Fieldbus)II1/2GD, EEx ia IIC T1...T6 (T1...T4 for PROFIBUS PA and FOUNDATION Fieldbus)II2G, EEx d [ia] IIC T1...T6 (T1...T4 for PROFIBUS PA and FOUNDATION Fieldbus)– FM<ul style="list-style-type: none">Class I/II/III Div. 1, Groups A...G– CSA<ul style="list-style-type: none">Class I/II/III Div. 1/2 Groups A...GClass II Div. 1, Groups E...GClass III <p>More information on the Ex-approvals can be found in the separate Ex-documentation.</p>
Pressure measuring device approval	Devices with a nominal diameter smaller than or equal to DN 25 correspond to Article 3 (3) of the EC Directive 97/23/EC (Pressure Equipment Directive). Optional approvals to Category III are also available for larger nominal diameters, where necessary (depending on fluid and process pressure). The devices are suitable for all media as well as unstable gases and have been designed and manufactured according to good engineering practice.
Certification FOUNDATION Fieldbus	<p>The flowmeter has successfully passed all test procedures and is certified and registered by the Fieldbus FOUNDATION. The device thus meets all the requirements of the specifications following:</p> <ul style="list-style-type: none">■ Certified to FOUNDATION Fieldbus Specification■ The device meets all the specifications of the FOUNDATION Fieldbus-H1.■ Interoperability Test Kit (ITK), revision status 4.5 (device certification number available on request): The device can also be operated with certified devices of other manufacturers.■ Physical Layer Conformance Test of the Fieldbus FOUNDATION
Certification PROFIBUS PA	<p>The flowmeter has successfully passed all test procedures and is certified and registered by the PNO (PROFIBUS User Organization). The device thus meets all the requirements of the specifications following:</p> <ul style="list-style-type: none">■ Certified to PROFIBUS PA Profile Version 3.0 (device certification number: on request)■ The device can also be operated with certified devices of other manufacturers (interoperability)

Other standards and guidelines

- EN 60529: Degrees of protection by housing (IP code).
- EN 61010: Protection measures for electrical equipment for measurement, control, regulation and laboratory procedures.
- EN 61326/A1: Electromagnetic compatibility (EMC requirements).
- NAMUR NE 21: Electromagnetic compatibility (EMC) of industrial process and laboratory control equipment.
- NAMUR NE 43: Standardization of the signal level for the breakdown information of digital transmitters with analog output signal.
- NACE Standard MR 0103: Standard Material Requirements - Materials Resistant to Sulfide Stress Cracking in Corrosive Petroleum Refining Environments
- NACE Standard MR 0175: Standard Material Requirements - Sulfide Stress Cracking Resistant Metallic Materials for Oilfield Equipment
- VDI 2643: Measurement of fluid flow by means of vortex flowmeters.
- ANSI/ISA-S82.01: Safety Standard for Electrical and Electronic Test, Measuring, Controlling and related Equipment - General Requirements. Pollution degree 2, Installation Category II
- CAN/CSA-C22.2 No. 1010.1-92: Safety Standard for Electrical Equipment for Measurement and Control and Laboratory Use. Pollution degree 2, Installation Category II
- The International Association for the Properties of Water and Steam - Release on the IAPWS Industrial Formulation 1997 for the Thermodynamic Properties of Water and Steam
- ASME International Steam Tables for Industrial Use (2000)
- American Gas Association (1962): A.G.A. Manual for the Determination of Supercompressibility Factors for Natural Gas - PAR Research Project NX-19.

Functional safety

Prowirl 72: SIL 2 in accordance with IEC 61508 / IEC 61511-1

Prowirl 73: SIL 1

Ordering information

Ordering information and detailed information on the order code can be obtained from your Endress+Hauser Service Organization.

Additional ordering information for Prowirl 72:

You can order your Prowirl 72 preconfigured.

For this purpose, the following information is needed when ordering:

- 20 mA value = at which measured value a current of 20 mA should be set
- Pulse value (if the device has a pulse output)

If you require the flow output in units of mass, we need:

- The average operating density of the fluid including the engineering unit to be used

If you require the flow output in units of corrected volume, we need:

- The operating and reference density of the fluid including the engineering unit to be used

The measuring device can be reset to the delivery state indicated in the order at any time.

Additional ordering information for Prowirl 73:

You can order your Prowirl 73 as preconfigured.

For this purpose, the following information is needed when ordering:

- Fluid (saturated steam, superheated steam, water or compressed air)
- Average operating pressure in bar absolute (not needed for saturated steam)
- 4 mA value = at which measured value (e.g. 50 kg/h) a current of 4 mA should be output, incl. engineering unit to be used
- 20 mA value = at which measured value (e.g. 1,000 kg/h) a current of 20 mA should be output, incl. engineering unit to be used
- Pulse value (if the device has a pulse output), incl. engineering unit to be used

The measuring device can be reset to the delivery state indicated in the order at any time.

Accessories

- Spare parts as per separate price list
- Wafer version mounting set
- Pipe and wall mounting kit for transmitter remote version DK5WM-B
- Replacement transmitter
- Universal flow and energy computer RMC 621
- Steam computer RMS 621
- Flow conditioner
- HART Communicator DXR 375 handheld terminal
- Active barrier preline RN 221 N
- Resistance thermometer Omnigrad TR10 (HART-enabled and burst-enabled, for delta heat applications with Prowirl 73)
- Pressure transmitter Cerabar M (HART-enabled and burst-enabled for superheated steam and gas applications with Prowirl 73)
- Pressure transmitter Cerabar T or Cerabar S (PROFIBUS PA, FOUNDATION Fieldbus)
- Process display RIA 250, RIA 251
- Field display unit RIA 261 or RID 261 (PROFIBUS PA)
- Applicator
- ToF Tool - Fieldtool Package
- Fieldgate FXA 520 (HART), FXA 720 (PROFIBUS PA) for data transmission
- Paperless Recorder Ecograph T for displaying, recording and communication of data

Documentation

- Operating Instructions Proline Prowirl 72
- Operating Instructions Proline Prowirl 72 PROFIBUS PA
- Operating Instructions Proline Prowirl 72 FOUNDATION Fieldbus
- Operating Instructions Proline Prowirl 73
- Operating Instructions Proline Prowirl 73 PROFIBUS PA
- Operating Instructions Proline Prowirl 73 FOUNDATION Fieldbus
- Related Ex-documentation
- Supplementary documentation on Pressure Equipment Directive

Registered trademarks

- GYLON®
Registered trademark of Garlock Sealing Technologies, Palmyra, NY, USA
- HART®
Registered trademark of the HART Communication Foundation, Austin, USA
- INCONEL®
Registered trademark of Inco Alloys International Inc., Huntington, USA
- KALREZ®, VITON®
Registered trademarks of E.I. Du Pont de Nemours & Co., Wilmington, USA
- ToF Tool - Fieldtool® Package, Fieldcheck®, Applicator®
Registered or registration-pending trademarks of Endress+Hauser Flowtec AG, Reinach, CH

Subject to modifications and amendments!
